

LYSAGHT® ZED & CEE PURLINS AND GIRTS

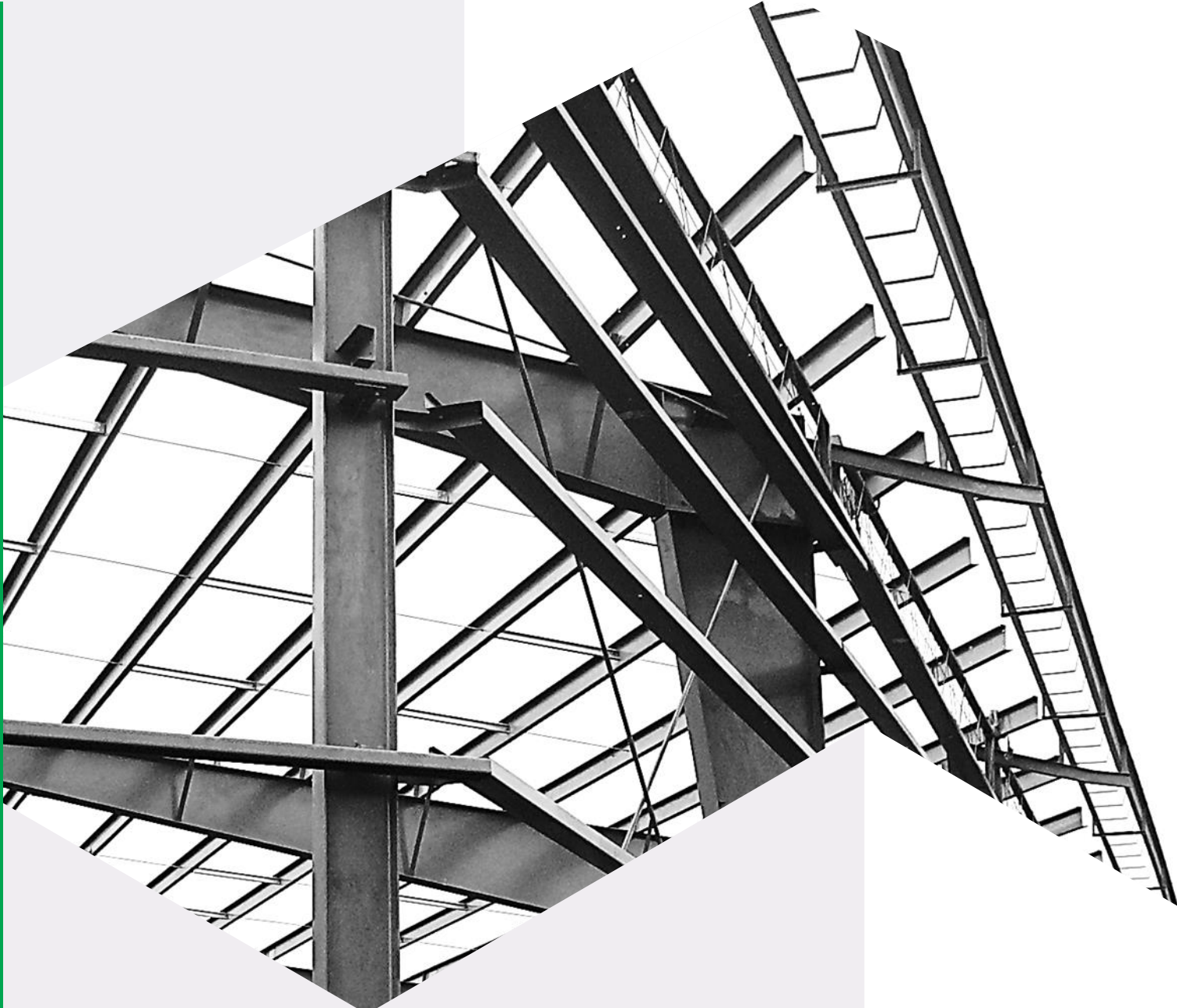

LYSAGHT

We're Your Best Partner for Your Roofing/Walling Solution



VISIT OUR
WEBSITE





LYSAGHT® ZED & CEE PURLINS AND GIRTS

LYSAGHT® Zed and Cee sections are accurately roll-formed from high-strength zinc-coated steel to provide an efficient, lightweight, economical roofing and cladding support system for framed structures.

Purlins and girts made from galvanized steel are proven performers, delivering cost-effective, design-efficient, highly-innovative building solutions.

APPLICATIONS

LYSAGHT® Zed sections may be used over single spans, lapped continuous and unlapped continuous spans in multi-bay buildings. Lapped continuous spans result in a considerable capacity increase in the system.

LYSAGHT® Cee sections may be used in single spans and unlapped continuous spans in multi-bay buildings. Cee sections are ideal as eave purlins or where compact sections are required for detailing. Cee sections cannot be lapped.

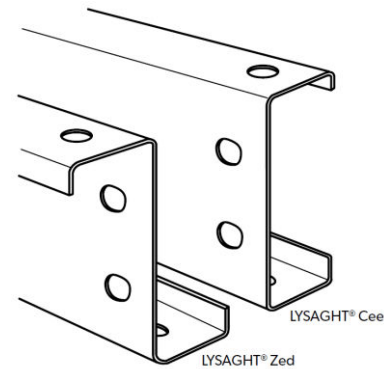

RANGE OF PRODUCTS & SERVICES

Our wide range includes:

- A full range of LYSAGHT® Zeds and Cees;
- A full range of LYSAGHT® Zeds and Cees with downturned-lip.
- Section sizes from 150mm to 350mm;
- Bolting systems to suit project needs.



PERFORMANCE

In accordance with the provisions of AS/ANZ 4600:1996 Cold-formed steel structures, load capacities have been calculated for LYSAGHT® sections using approved LYSAGHT® bridging systems, bolting and other accessories. Sections chosen using the data provided in the tables will perform as specified when the design, fabrication and erection are carried out in accordance with Lysaght recommendations and accepted building practice.

STANDARD RANGE OF LYSAGHT® ZED & CEE

Nominal Section Size

Nominal Section Size (mm) Zed & Cee	BMT (mm)
100	1.2; 1.5; 1.9
150	1.2; 1.5; 1.9; 2.4
200	1.5; 1.9; 2.4
250	1.9; 2.4
300	2.4; 3.0
350	3.0

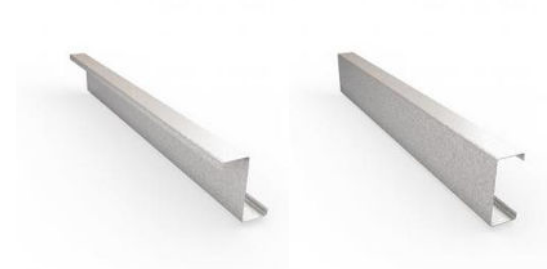

NON-STANDARD SECTIONS

We can supply a wide range of non-standard sizes (up to 350mm) and shapes, including Cees and Zeds with downturned lip – the Zeds can also be made to lap.

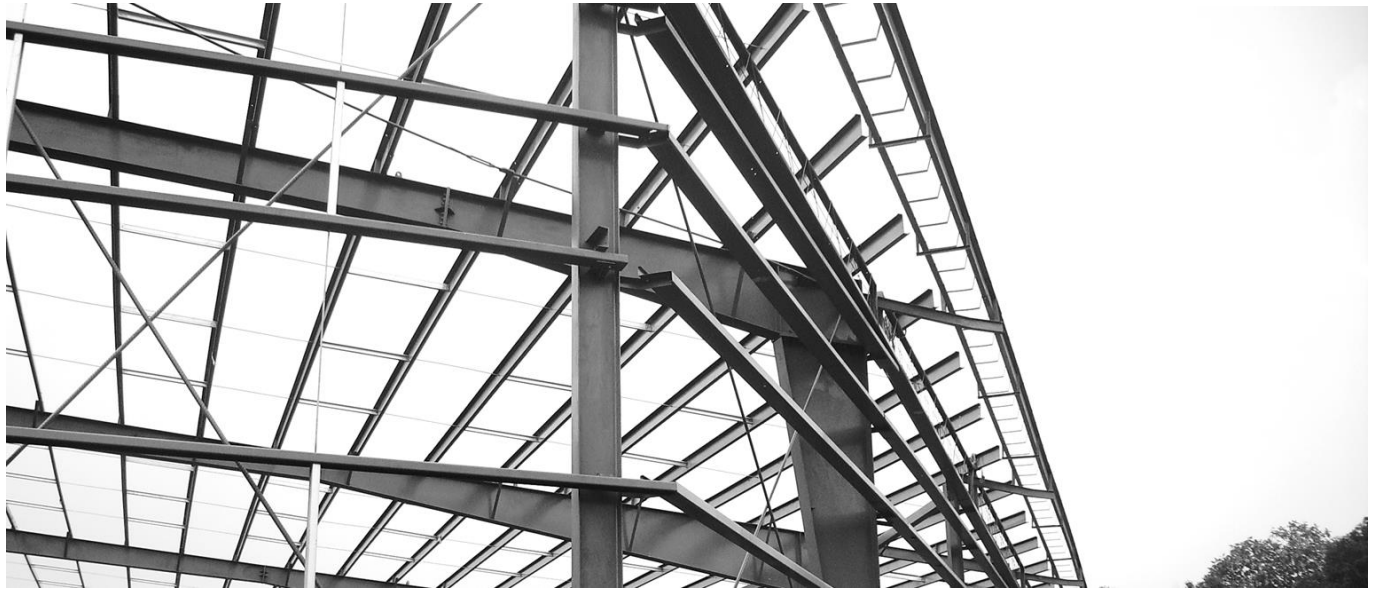

MATERIAL SPECIFICATION

LYSAGHT® Zed and Cee purlins are rollformed from galvanized steel with hot dipped, zinc-coated, chromate-passivated and high strength grade steel strip complying with AS1397-1993. In the grades shown, the number prefixed with G indicates minimum yield stress in MPa; and the number prefixed with Z indicates minimum coating mass in gr/m²

Thickness (mm BMT)	Coating Mass (gr/m ²)	Yield Stress (MPa)	Standard
1.2	Z275	G450	AS 1397-1993
1.5	Z275	G450	AS 1397-1993
1.9	Z275	G450	AS 1397-1993
2.4	Z275	G450	AS 1397-1993
3.0	Z275	G450	AS 1397-1993

AVAILABLE LENGTHS

LYSAGHT® purlins are available custom-cut in any transportable length, however there are some limitations.

Minimum length is 2000 mm and maximum length is 14000 mm. For normal deliveries nominal lengths should not exceed 12000 mm. Lengths greater than 12000 mm require special transportation and on-site handling facilities. Law restricts the hours of transportation and permits may be required.

Length tolerance for all sections is ± 5 mm.

PACKING

LYSAGHT® Zed & Cee sections are delivered in strapped bundles. The actual quantity in each bundle will vary with section size, order and length.

LYSAGHT® products accessories are delivered in strapped or wired bundles, bags, or packages as appropriate.

STORAGE ON-SITE

If not required for immediate use, sections should be neatly stacked off the ground and on a slight slope so that water can drain away. Sections and accessories should not be left exposed in the open for extended periods.

ZED & CEE SECTIONS – DIMENSIONS AND PROPERTIES

LYSAGHT® ZED SECTIONS

LYSAGHT® Zed sections feature one broad and one narrow flange, sized so that two sections of the same size fit together snugly, making them suitable for lapping. Continuous lengths of purlin result in better economy but lapping provides two thicknesses of metal over interior supports. Lapping increases the strength of the sections where bending moments and shear are at a maximum, thus improving the load capacity and rigidity of the system.

LYSAGHT® Zed sections of the same depth and different thicknesses can be lapped in any combination.



LYSAGHT® Zed sections may also be used over simple spans. For shorter spans they may be used continuously over two or more spans without laps – thus producing reduced deflection compared with simple spans – but it does not give the strength of a fully lapped system. LYSAGHT® Zed sections with one lip turned outward (called downturned lip purlins) may be used in simple or continuous spans with the ends butted.

LYSAGHT® CEE SECTIONS

LYSAGHT® Cee sections have equal flanges and are suitable for simply supported spans. For shorter spans they may be used continuously over two or more spans with the ends butted, thus producing reduced deflection compared with simple spans. They cannot be lapped.

Zed Section

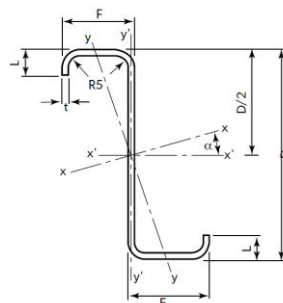

Cee Section

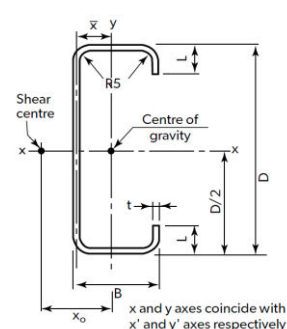

DIMENSIONS OF ZEDS & CEES

Catalogue Number	t mm	D mm	Mass per unit length kg/m	Zeds			Cees	
				E mm	F Mm	L Mm	B mm	L mm
Z/C10012	1.2	102	2.10	53	49	12.5	51	13.5
Z/C10015	1.5	102	2.62	53	49	13.5	51	14.0
Z/C10019	1.9	102	3.29	53	49	14.5	51	15.5
Z/C15015	1.5	152	3.59	65	61	16.5	64	16.0
Z/C15019	1.9	152	4.51	65	61	17.5	64	17.5
Z/C15024	2.4	152	5.70	66	60	19.5	64	19.0
Z/C20015	1.5	203	4.49	79	74	16.0	76	16.0
Z/C20019	1.9	203	5.74	79	74	20.0	76	19.5
Z/C20024	2.4	203	7.24	79	73	21.5	76	21.5
Z/C25019	1.9	254	6.50	79	74	19.0	76	19.5
Z/C25024	2.4	254	8.16	79	73	21.0	76	21.0
Z/C30024	2.4	300	10.09	100	93	28.0	96	27.5
Z/C30030	3.0	300	12.76	100	93	29.5	96	29.5
Z/C35030	3.0	350	15.23	129	121	31.5	125	30.5

SECTION PROPERTIES LYSAGHT® ZEDS

Product Code	Area	Principal Axes					Axes Perpendicular & Parellel To Web								Column Properties		Effective Section Properties At Yield Stress	
		Second Moment Of Area		Section Modulus	Radius Of Gyration		Second Moment Of Area		Product Moment Of Area	Section Modulus		Radius Of Gyration		Torsion Constant	Warping Constant	Section Modulus In Bending	Area Compression	
		A mm ²	Ix 10 ⁶ mm ⁴	Iy 10 ⁶ mm ⁴	Zy 10 ³ mm ³	ry mm	a (°)	Ix ¹ 10 ⁶ mm ⁴	Iy ¹ 10 ⁶ mm ⁴	Ix ¹ Iy ¹ 10 ⁶ mm ⁴	Zx ¹ 10 ³ mm ³	Zy ¹ 10 ³ mm ³	rx ¹ mm	ry ¹ mm	J Mm ⁴	Iw 10 ⁶ mm ⁶	Zx ¹ e 10 ³ mm ³	Ae mm ²
Z10012	258	0.536	0.0516	1.84	14.2	27.5	0.432	0.155	0.198	8.32	3.02	41.0	24.5	124	253	6.73	153	
Z10015	323	0.668	0.0652	2.32	14.2	27.8	0.537	0.197	0.249	10.3	3.84	40.8	24.7	242	321	8.82	217	
Z10019	409	0.840	0.0829	2.94	14.2	28.1	0.673	0.250	0.314	13.0	4.92	40.6	24.7	492	409	12.4	329	
Z15015	443	1.84	0.145	3.96	18.1	22.0	1.60	0.383	0.588	20.8	6.06	60.1	29.4	332	1460	17.2	248	
Z15019	561	2.32	0.184	5.02	18.1	22.1	2.01	0.487	0.744	26.1	7.73	59.9	29.5	675	1860	22.4	347	
Z15024	712	2.92	0.238	6.38	18.3	22.5	2.53	0.632	0.950	32.6	10.0	59.6	29.8	1370	2410	31.4	535	
Z20015	555	3.89	0.255	5.53	21.4	18.5	3.53	0.621	1.09	34.3	8.05	79.7	33.4	416	4260	23.8	248	
Z20019	713	5.02	0.342	7.45	21.9	19.1	4.52	0.843	1.45	43.9	11.0	79.6	34.4	858	5830	36.4	378	
Z20024	907	6.36	0.443	9.64	22.1	19.4	5.70	1.10	1.86	55.3	14.4	79.3	34.8	1740	7630	48.4	546	
Z25019	808	8.08	0.381	7.82	21.7	14.0	7.62	0.833	1.81	59.3	10.8	97.1	32.1	972	9480	45.7	379	
Z25034	1030	10.2	0.493	10.2	21.9	14.3	9.64	1.08	2.33	74.9	14.2	96.9	32.5	1970	12400	66.0	547	
Z30024	1260	18.3	1.01	16.8	28.3	16.0	17.0	2.32	4.57	112	23.8	116	42.8	2430	36600	89.9	628	
Z30030	1600	23.1	1.32	21.9	28.7	16.3	21.3	3.04	5.88	140	31.4	116	43.6	4790	48200	125	908	
Z35030	1910	39.2	2.49	32.8	36.1	17.8	35.8	5.93	10.7	202	47.2	137	55.7	5730	124000	159	940	



LYSAGHT® CEES

Product Code	Area	Full Section Properties						Column Properties					Effective Section Properties At Yield Stress	
		Second Moment Of Area		Section Modulus		Radius Of Gyration		Centroid	Shear Centre	Torsion Constant	Warping Constant	Monosymmetry Section Constant	Section Modulus In Bending	Area Compression
		A mm ²	I _x 10 ⁶ mm ⁴	I _y 10 ⁶ mm ⁴	Z _x 10 ³ mm ³	Z _y 10 ³ mm ³	r _x mm							
C10012	258	0.432	0.0892	8.48	2.59	41.0	18.6	16.0	39.7	124	188	123	6.74	153
C10015	323	0.537	0.112	10.5	3.29	40.8	18.7	16.1	40.1	242	241	122	8.73	217
C10019	409	0.673	0.142	13.2	4.21	40.6	18.7	16.2	40.4	492	311	122	12.3	329
C15015	443	1.61	0.237	21.1	5.29	60.2	23.1	18.4	46.9	332	1070	171	17.1	244
C15019	561	2.02	0.300	26.6	6.74	60.0	23.1	18.5	47.1	675	1370	170	21.8	340
C15024	712	2.54	0.386	33.5	8.79	59.8	23.3	18.9	48.0	1370	1810	169	30.9	527
C20015	555	3.53	0.396	34.7	7.17	79.7	26.7	19.9	51.6	416	3060	223	24.1	251
c20019	713	4.51	0.531	44.4	9.77	79.6	27.3	20.8	53.6	858	4240	221	36.6	381
C20024	904	5.69	0.681	56.0	12.7	79.3	27.4	21.1	54.4	1740	5540	219	47.5	541
C25019	808	7.62	0.561	60.0	9.86	97.1	26.4	18.1	48.5	972	6860	276	46.2	381
C25034	1020	9.62	0.721	75.7	12.8	96.9	26.5	18.4	49.3	1970	8920	274	64.9	543
C30024	1260	17.0	1.51	113	21.7	116	34.6	25.0	66.0	2430	26800	320	91.1	632
C30030	1600	21.3	1.96	142	28.5	116	35.0	25.8	67.9	4790	35700	316	124	897
C35030	1910	35.8	3.82	205	42.3	137	44.7	33.2	86.3	5730	90000	378	159	940

LAP LENGTHS

Nominal Section Size (mm)	Span (mm)	Lap Length (mm)
100	≤6000	600
	>6000	900
150, 200, 250	≤9000	900
	>9000 ≤12000	1200
	>12000*	1800

Nominal Section Size (mm)	Span (mm)	Lap Length (mm)
300, 350	≤9000	900
	>9000 <12000	1200
	>12000 ≤18000	1800
	>18000*	2400

* Load capacities for these spans are beyond the scope of this publication

CLEAT CONNECTIONS

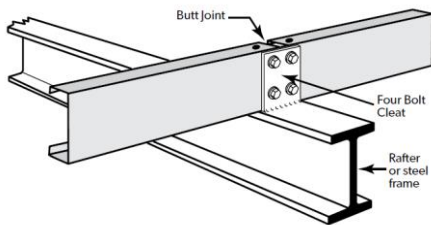

CLEATLESS CONNECTIONS

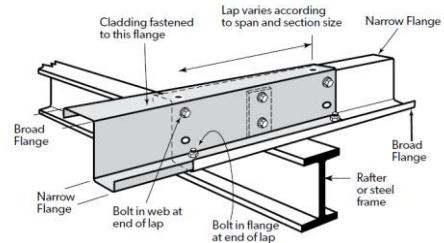

CORROSION PROTECTION AND MATERIAL COMPATIBILITY

Some building materials and environmental conditions can be detrimental to coated steel products. These include contact with or exposure to run-off from:

- Industrial, agricultural, marine or other aggressive atmospheric conditions;
- Incompatible metals, like lead or copper;
- Building materials subject to cycles of dryness and wetness, or which have excessive moisture content such as improperly seasoned timber.
- Materials which have been treated with preservatives, like cca or tanalith-treated timber.

A zinc coating of Z275 (275 g/m² minimum coating mass) is the standard coating class provided with LYSAGHT® Zed & Cee sections. This will provide a long and trouble-free life. for enclosed buildings and open-sided rural buildings, in a non-aggressive environment.

A non-aggressive environment is 1000m from rough surf, 750m from industrial emission and fossil fuel combustion, and 300m from calm salt waters. Consideration must be given to the nature of activities performed within the building.

Direct contact of incompatible materials with the coating must be avoided. In such applications, and in very corrosive environments, suitable paint systems can be obtained from paint manufacturers.

The BlueScope technical information booklet on painting zinc-coated or ZINCALUME® steel sheets may offer guidance.

In applications where particular attention is required for corrosion, or the buildup of substances like dust or grain, then consideration should be given to the shape of the sections (either Zed, or Cee, or Zed with downturned lip); orientation of the sections; and coating class.

We're Your Best Partner for Your Roofing/Walling Solution

PRODUCT DESCRIPTIONS

All descriptions, specifications, illustrations, drawings, data, dimensions and weights contained in this catalogue, all technical literature and websites containing information from Lysaght are approximations only. They are intended by Lysaght to be a general description for information and identification purposes and do not create a sale by description. Lysaght reserves the right at any time to:

- (a) supply Goods with such minor modifications from its drawings and specifications as it sees fit; and
- (b) alter specifications shown in its promotional literature to reflect changes made after the date of such publication.

DISCLAIMER, WARRANTIES AND LIMITATION OF LIABILITY

- This publication is intended to be an aid for all trades and professionals involved with specifying and installing Lysaght products and not to be a substitute for professional judgement.
- Terms and conditions of sale available at local Lysaght sales offices.
- Except to the extent to which liability may not lawfully be excluded or limited, BlueScope Steel Limited will not be under or incur any liability to you for any direct or indirect loss or damage (including, without limitation, consequential loss or damage such as loss of profit or anticipated profit, loss of use, damage to goodwill and loss due to delay) however caused (including, without limitation, breach of contract, negligence and/or breach of statute), which you may suffer or incur in connection with this publication.

VISIT OUR WEBSITE



WWW.LYSAGHTASEAN.COM

® product and product brand names are registered trademarks and ™ product and product brand names are trademarks of BlueScope Steel Limited.

The LYSAGHT® range of products is exclusively made by or for BlueScope Steel Limited.

BlueScope and the BlueScope brand mark are registered trademarks of BlueScope Steel Limited.

© PT NS BlueScope Lysaght Indonesia July 2025. All rights reserved.



Our Office & Factory

Bekasi

Jalan Irian blok DD2-2, Kawasan Industri MM2100, Cibitung, Bekasi, JAWA BARAT

Surabaya

Jalan Rungkut Industri IV No.24, Kawasan Industri SIER, Rungkut Tengah, Gunung Anyar, Surabaya, JAWA TIMUR

CONTACT US AT

- ✉ sales@paramasteel.id
- ☎ 021 5853 738
- ☎ +62 821 1273 1111



FOLLOW US AT

- 📷 parama_id
- 📺 paramasteel.id

VISIT US

Perkantoran Taman Kebon Jeruk Intercon, Blok AA4 No. 16-18, Meruya Selatan, Jakarta Barat – 11650

