

PRESTIGE PANEL® II

A versatile cladding profile with concealed fastening ideal for applications where a clean flat surface is desired such as walls, ceilings, fascias and fencing.

LYSAGHT® PRESTIGE PANEL® II can be laid vertically or horizontally. The choice of direction implies different aesthetics and technical solutions for the main flashings.

PROFILE DETAILS

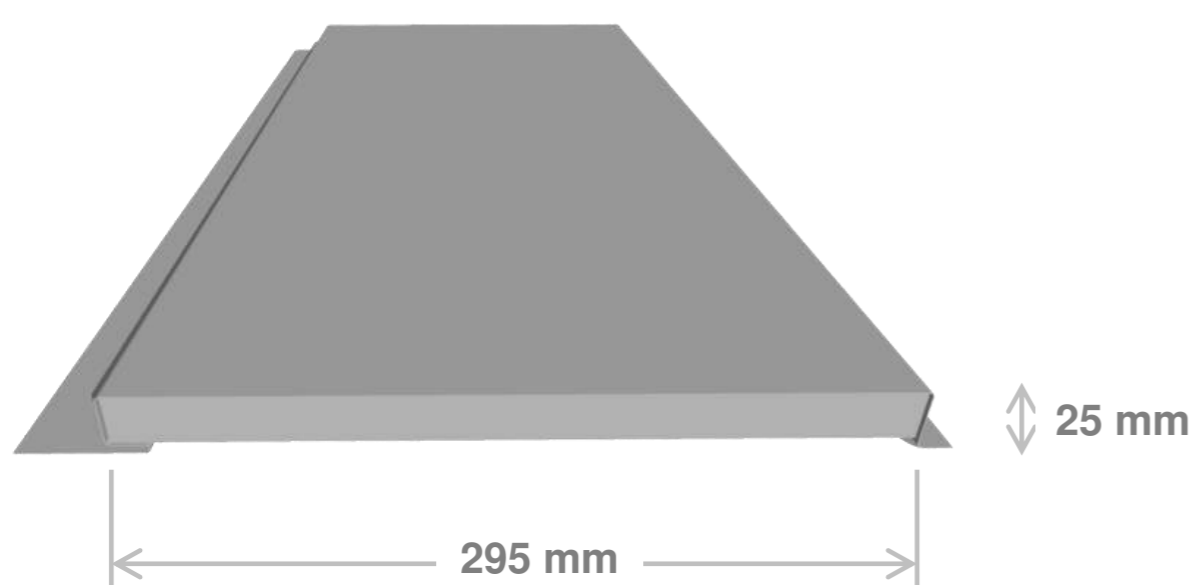

PROFILE PROPERTIES

Application	Walling
Shape Capability	Straight
Finishes Available	ZINCALUME® Steel COLORBOND® Steel
Effective Width	295 mm
Rib Depth	25 mm
Pan Width	295 mm
Rib Distance	Not applicable
Standard Thickness (BMT)	0.55 mm
Roof Length <i>(Manufactured in factory)</i>	Min. 1000 mm Max. 3000 mm
Tolerance	Length +10 mm; -0 mm Effective Width ± 3 mm
Minimum Roof Slope	Not suitable for roofing

Material Specification

ZINCALUME® steel complying with AS1397-2001 G300, AZ150 (300 MPa minimum yield stress, 150gr/m² minimum coating mass).

COLORBOND® steel complies with AS/NZ2728:1997.

PROFILE WEIGHT (KG/M²)

THICKNESS (BMT)	COLORBOND® XRW	ZINCALUME®
0.55 mm	6.18	6.26

MAXIMUM SUPPORT SPACING

WALLS (without wind load)

THICKNESS (mm BMT)	Single (mm)	End (mm)	Internal (mm)
0.55	1200	1200	1500

WIND UPLIFT CAPACITY (kPa)

THICKNESS 0.55 mm BMT

Support	Limit State	Span (mm)	
		450	600
Plywood min. 15 mm	Serv.	1.07	
	Strength	4.23	
Steel Batten min. 0.75 mm BMT	Serv.		1.58
	Strength		4.33

These capacities are based on tests conducted at BlueScope's NATA registered testing laboratory using a direct pressure testing rig. Testing was conducted in accordance with AS 1562.1—1992 design and installation of Sheet Roof And Wall Cladding—Metal, and AS 4040.2—1992 resistance to Wind Pressure For Non-Cyclonic Regions. The pressure capacities for serviceability are based on a deflection limit of (span/120) + (maximum fastener pitch/30). The pressure capacities for strength have been determined by testing the cladding to failure (ultimate capacity). These pressures are applicable when the cladding is fixed to a minimum of 1.0 mm, G550 steel.

FASTENING METHOD

LYSAGHT® PRESTIGE PANEL® II cladding is screw-fixed to supports. Engage the overlap leg into the underlap recess, then fix the nominated fastener through both legs into batten or plywood support. When the screw is properly tightened into metal there should be a minimum of three (3) threads protruding past the support being fixed in to. For timber the screw must have a min. embedment of 25 mm into the timber.

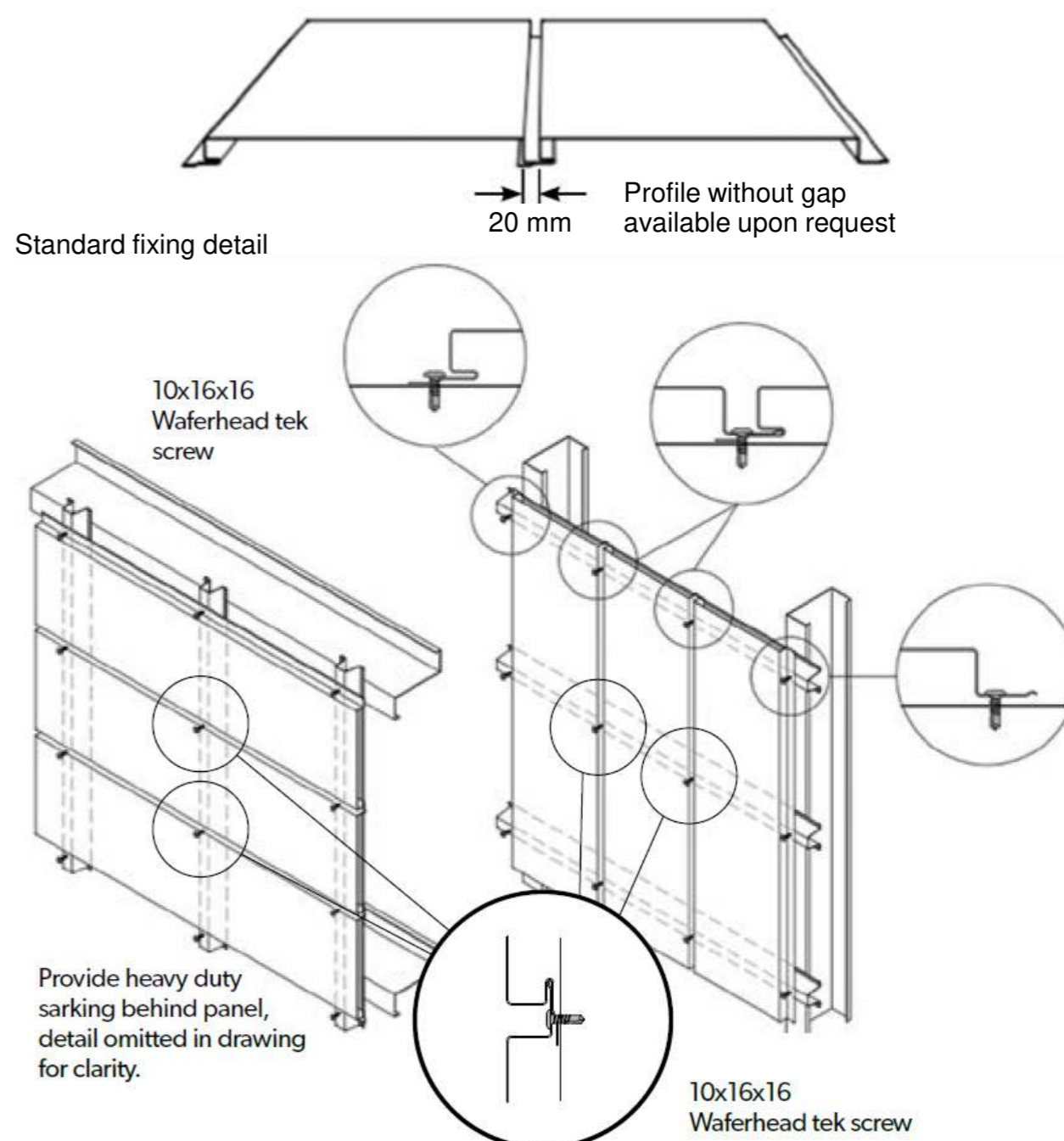

Express joint detail

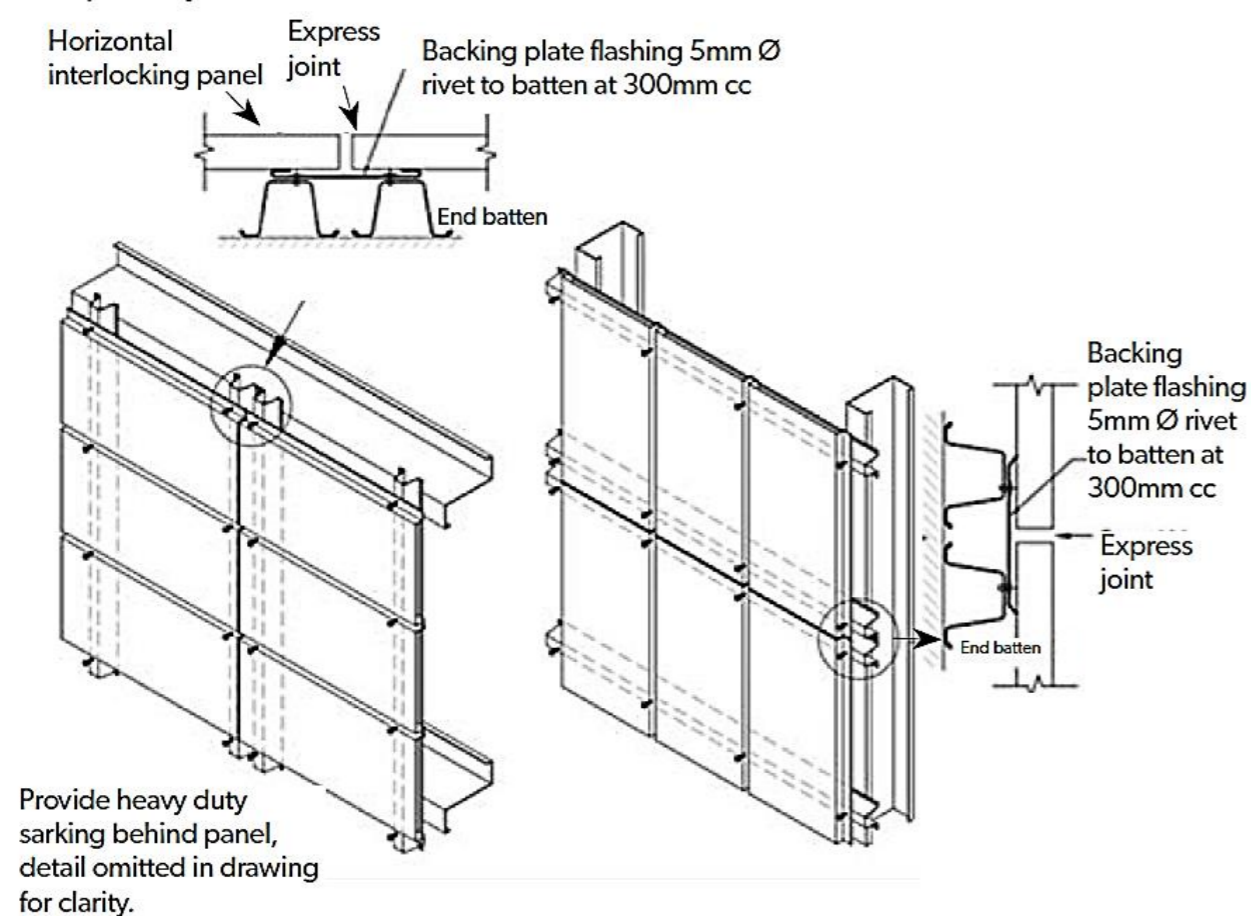

Top of facade

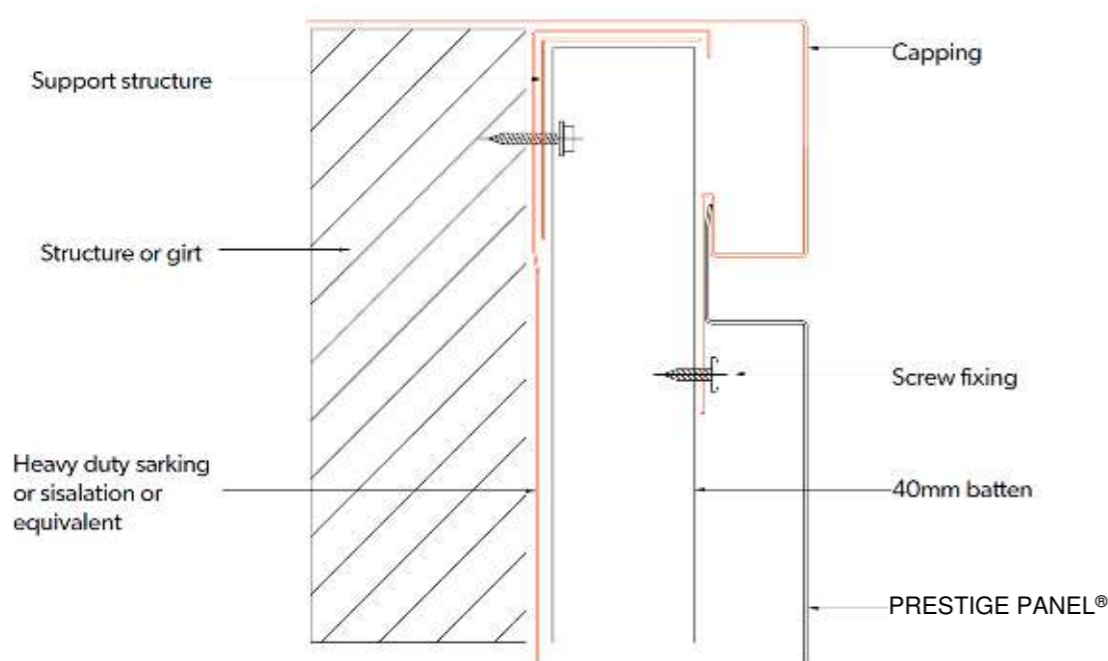

Bottom of facade

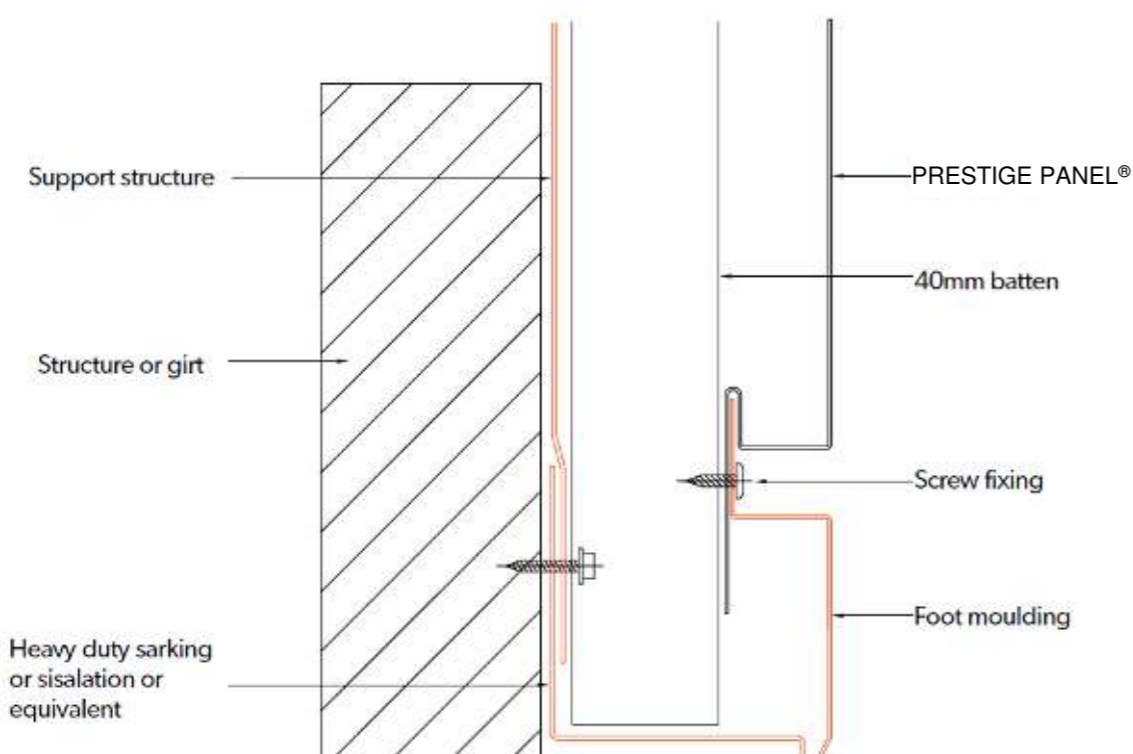

OVERLAPPING

No overlapping. Refer to express joint detail for sheet length > 3000 mm.

MANUFACTURING

LYSAGHT® PRESTIGE PANEL® II produced in Cibitung factory.

OIL CANNING

OIL CANNING can be defined as a perceived waviness in the flat areas of metal roofing and metal cladding panels. Generally the period and amplitude of the wave depend on the continuous width of the flat section of the profile. Oil canning is an inherent part of light gauge cold formed metal products, particularly those with broad flat areas.

Since many uncontrollable factors are involved, no manufacturer can realistically assure the total elimination of oil canning. With careful attention to the production and selection of material, to the panel design, and to installation practice, oil canning can be effectively minimised.

Unless specific tolerances have been incorporated into the contract documents and accepted by the panel provider and panel manufacturer, and if reasonable precautions have been taken, oil canning is not grounds for panel rejection.

COLOR CHOICE

Standard & Non-standard colors can be selected from Colorbond® brochure available in www.colorbond.id/product.

CERTIFICATION

- Green Label Indonesia
- TKDN

VISIT OUR WEBSITE



CONTACT US AT

- ✉ sales@paramasteel.id
- ☎ 021 5853 738
- ☎ +62 821 1273 1111



FOLLOW US AT

- 📷 parama_id
- 📺 paramasteel.id

VISIT US

Perkantoran Taman Kebon Jeruk Intercon, Blok AA4 No. 16-18, Meruya Selatan, Jakarta Barat – 11650

WWW.LYSAGHTASEAN.COM

® product and product brand names are registered trademarks and ™ product and product brand names are trademarks of BlueScope Steel Limited. The LYSAGHT® range of products is exclusively made by or for BlueScope Steel Limited. BlueScope and the BlueScope brand mark are registered trademarks of BlueScope Steel Limited.

© PT NS BlueScope Lysaght Indonesia June 2022. All rights reserved.

