

KLIP-LOK® OPTIMA

LYSAGHT® KLIP-LOK® OPTIMA is an advancement of the original concealed fix roof cladding with bolder ribs and subtle transverse fluting on the pans provides wider coverage and visual appeal.

Concealed fastening offers excellent water tightness and control of thermal expansion.

PROFILE DETAILS

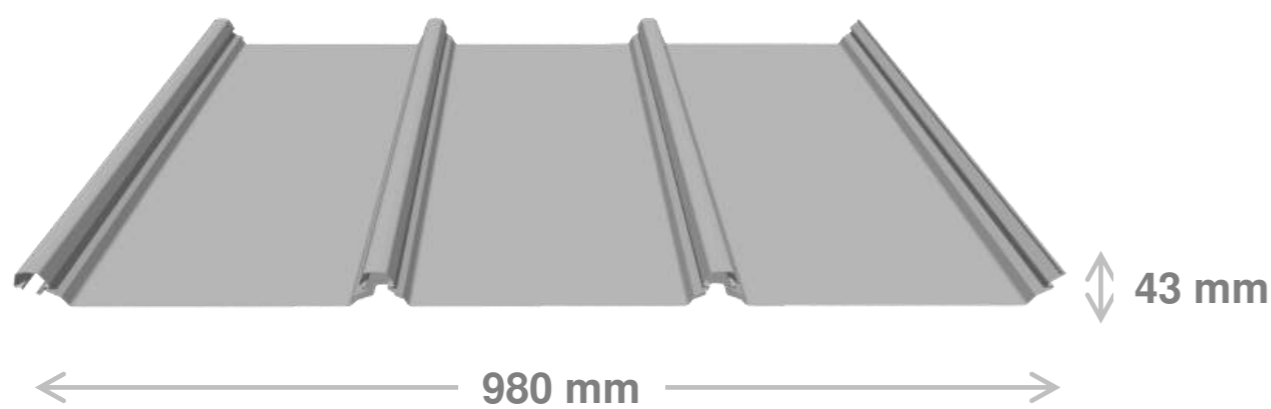

PROFILE PROPERTIES

Application	Roofing
Shape Capability	Straight and Spring Curve Sheets
Finishes Available	ZINCALUME® Steel COLORBOND® Steel
Effective Width	980 mm
Rib Depth	43 mm
Pan Width	266 mm
Rib Distance	326 mm
Standard Thickness (BMT)	0.40 – 0.45 mm
Roof Length <i>(Manufactured in factory)</i>	Min. 500 mm Max. 20000 mm
Tolerance	Length +10 mm; -0 mm Effective Width ± 5 mm
Minimum Roof Slope	2°
Curving Data	Spring Curve R+ >80m
<i>Convex (R+)</i>	
<i>Concave (R-)</i>	

Material Specification

ZINCALUME® steel complying with AS1397-2001 G550, AZ150 (550 MPa minimum yield stress, 150gr/m² minimum coating mass).

COLORBOND® steel complies with AS/NZ2728:1997.

PROFILE WEIGHT (KG)

THICKNESS (BMT)	COLORBOND® XRW	ZINCALUME®
0.40 mm	4.17	4.10
0.45 mm	4.66	4.59

MAXIMUM SUPPORT SPACING

ROOFS

THICKNESS (mm BMT)	Single (mm)	End (mm)	Internal (mm)
0.40	800	800	1200
0.45	925	1050	1825

WIND UPLIFT CAPACITY (kPa)

THICKNESS 0.40 mm BMT

Span	Limit State	Span (mm)					
		900	1200	1500	1800	2100	2400
Single	Serv.	0.91	0.80	0.70	0.61	0.52	0.45
	Strength	1.89	1.76	1.63	1.49	1.35	1.20
End	Serv.	0.73	0.71	0.69	0.66	0.63	0.58
	Strength	1.70	1.53	1.36	1.19	1.04	0.93
Internal	Serv.	0.65	0.62	0.60	0.59	0.58	0.56
	Strength	1.81	1.63	1.47	1.34	1.23	1.15

THICKNESS 0.45 mm BMT

Span	Limit State	Span (mm)					
		900	1200	1500	1800	2100	2400
Single	Serv.	1.02	0.91	0.81	0.72	0.62	0.54
	Strength	2.17	1.94	1.71	1.51	1.36	1.21
End	Serv.	1.03	1.01	0.98	0.91	0.83	0.73
	Strength	2.08	2.03	1.98	1.77	1.49	1.24
Internal	Serv.	0.98	0.97	0.95	0.92	0.84	0.75
	Strength	2.03	1.94	1.81	1.60	1.39	1.22

These capacities are based on tests conducted at BlueScope's NATA registered testing laboratory using a direct pressure testing rig. Testing was conducted in accordance with AS 1562.1—1992 design and installation of Sheet Roof And Wall Cladding—Metal, and AS 4040.2—1992 resistance to Wind Pressure For Non-Cyclonic Regions. The pressure capacities for serviceability are based on a deflection limit of (span/120) + (maximum fastener pitch/30). The pressure capacities for strength have been determined by testing the cladding to failure (ultimate capacity). These pressures are applicable when the cladding is fixed to a minimum of 1.0 mm, G550 steel.

ROOF DRAINAGE (length of sheet in m')

Rainfall Intensity (mm/hour)	Slope (°)			
	3	5	7	10
100	588	735	873	1003
200	294	366	436	502
300	196	244	291	334
400	147	183	218	251
500	118	146	175	201

FASTENING METHOD

LYSAGHT® KLIP-LOK® OPTIMA is a concealed-fixed profile. Concealed-fixing is the method of fixing sheets using fasteners which do not pass through the sheet. Instead, the cladding is held in place with clips.

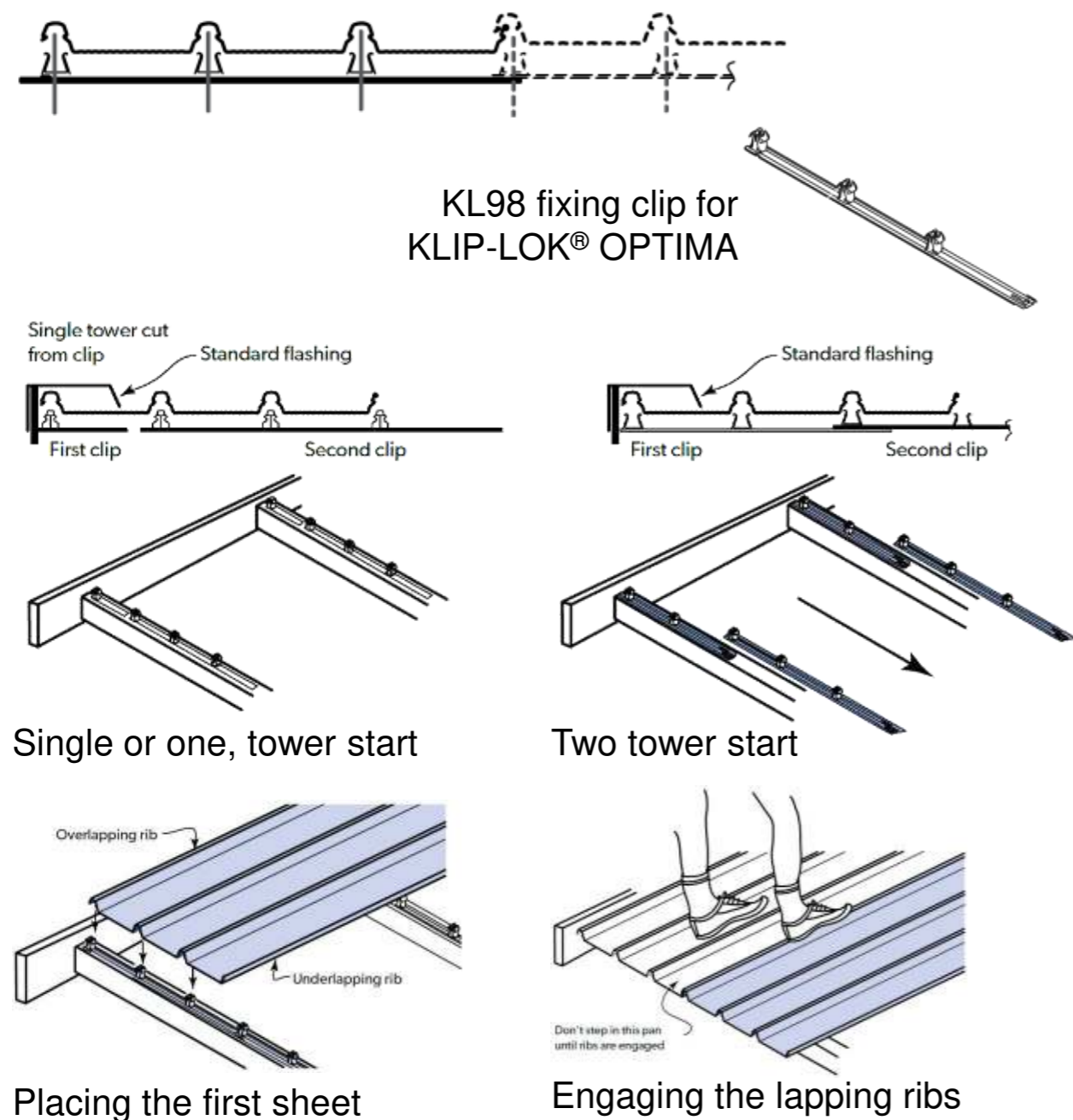

CLIPS & FASTENERS ESTIMATION:
 Number of clips = (number of supports) x (number of sheets)
 Number of fasteners = number of clips x 3

LYSAGHT® KLIP-LOK® OPTIMA is using 12-14x30 Hex Head with corrosion class 3 screw for roof without insulation or with maximum 10 mm thickness insulation. It is recommended to use spacer for thicker insulation such as mineral wool.

Pierce-fixing of concealed-fixed claddings is not normally recommended. Please contact us for guidance.

To prevent concealed-fixed cladding from sliding downward in the fixing clips, on very steep pitches, you should pierce-fix through each sheet under the flashing or capping, along the top of the sheets, but not less than 25mm from the ends of a sheet.

OVERLAPPING

LYSAGHT® KLIP-LOK® OPTIMA is not recommended to be end-lapped. Ideally long length sheets from a mobile rollformer should be used where possible. If the need for end-lapping can not be avoided, contact us for guidance.

MANUFACTURING

LYSAGHT® KLIP-LOK® OPTIMA produced in Cibitung and Sidoarjo factory.

Also available in extra long lengths, produced by our on-site mobile rollformer/roll on-site. This service is available based on enquiry.

OIL CANNING

OIL CANNING can be defined as a perceived waviness in the flat areas of metal roofing and metal cladding panels. Generally the period and amplitude of the wave depend on the continuous width of the flat section of the profile. Oil canning is an inherent part of light gauge cold formed metal products, particularly those with broad flat areas.

Since many uncontrollable factors are involved, no manufacturer can realistically assure the total elimination of oil canning. With careful attention to the production and selection of material, to the panel design, and to installation practice, oil canning can be effectively minimised.

Unless specific tolerances have been incorporated into the contract documents and accepted by the panel provider and panel manufacturer, and if reasonable precautions have been taken, oil canning is not grounds for panel rejection.

COLOR CHOICE

Standard & Non-standard colors can be selected from Colorbond® brochure available in www.colorbond.id/product.

CERTIFICATION

- Green Label Indonesia
- TKDN

VISIT OUR WEBSITE



CONTACT US AT

- ✉ sales@paramasteel.id
- ☎ 021 5853 738
- ☎ +62 821 1273 1111



FOLLOW US AT

- 📷 parama_id
- 📺 paramasteel.id

VISIT US

Perkantoran Taman Kebon Jeruk Intercon, Blok AA4 No. 16-18, Meruya Selatan, Jakarta Barat – 11650

WWW.LYSAGHTASEAN.COM

® product and product brand names are registered trademarks and ™ product and product brand names are trademarks of BlueScope Steel Limited. The LYSAGHT® range of products is exclusively made by or for BlueScope Steel Limited. BlueScope and the BlueScope brand mark are registered trademarks of BlueScope Steel Limited.