

FLEX-LOK®

LYSAGHT® FLEX-LOK® standing seam profile is the latest addition to LYSAGHT® suite of products.

Unlike our range of architectural standing seam profile, this roofing system requires no substrate as it is profiled with structural strength to function as a single skin roof to increase its ability in thermal resistance and sound transmission.

PROFILE DETAILS

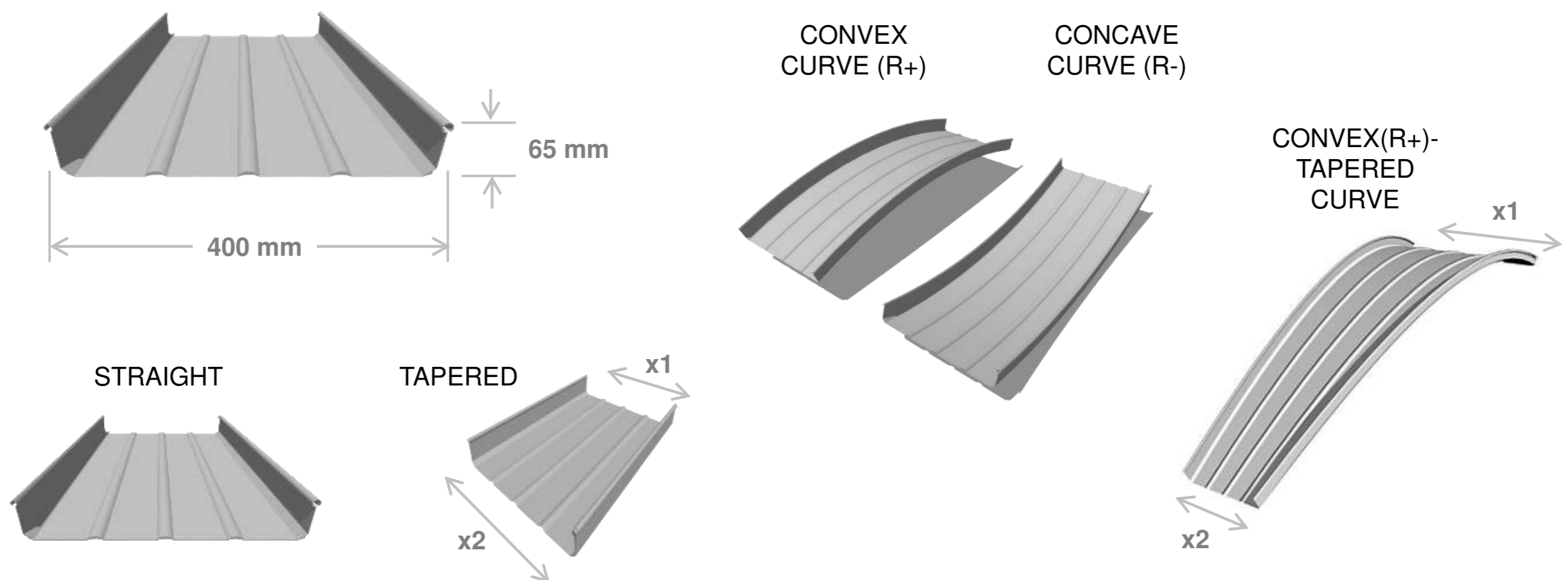

PROFILE PROPERTIES

Application	Roofing
Shape Capability	Straight, Spring Curve, Smooth Curve, Tapered and Smooth Curve-Tapered Sheets
Finishes Available	ZINCALUME® Steel COLORBOND® Steel
Standard Effective Width	400 mm
Tapered Width	240 mm ~ 500 mm
Rib Depth	65 mm
Pan Width	395 mm
Rib Distance	400 mm
Standard Thickness (BMT)	0.55 mm for Steel 0.80 mm for Aluminium
Roof Length <i>(Manufactured in factory)</i>	Min. 1500 mm Max. 16000 mm
Tolerance	Length +10 mm; -0 mm Effective Width ± 5 mm
Minimum Roof Slope	1.4°
Curving Data	Spring Curve R+ 60 m min.; R- 80 m min. Smooth Curve Straight R+ 12 m; R- 14m min. Tapered R+/- 22 m min.
<i>Convex (R+)</i>	
<i>Concave (R-)</i>	

Material Specification

ZINCALUME® steel complying with AS1397-2001 G300, AZ150 (300 MPa minimum yield stress, 150gr/m² minimum coating mass).

COLORBOND® steel complies with AS/NZ2728:1997.

PROFILE WEIGHT (KG/M²)

THICKNESS (BMT)	COLORBOND® XRW	ZINCALUME®
0.55 mm	6.57	6.49

MAXIMUM SUPPORT SPACING

THICKNESS (mm BMT)	Single (mm)	End (mm)	Internal (mm)
0.55 (steel)	800	100	1200

VISIT OUR WEBSITE



WIND UPLIFT CAPACITY (kPa)

THICKNESS 0.55 mm BMT (Steel)

Span	Limit State	Span (mm)					
		900	1200	1500	1800	2100	2400
Single	Serv.	1.10	0.99	0.89	0.80	0.71	0.63
	Strength	2.40	1.90	1.45	1.10	0.85	0.75
End	Serv.	0.63	0.58	0.55	0.53	0.52	0.53
	Strength	1.40	1.20	1.05	0.95	0.85	0.80
Internal	Serv.	0.58	0.53	0.50	0.48	0.48	0.52
	Strength	1.20	1.10	1.00	0.95	0.90	0.90

These capacities are based on tests conducted at BlueScope's NATA registered testing laboratory using a direct pressure testing rig. Testing was conducted in accordance with AS 1562.1—1992 design and installation of Sheet Roof And Wall Cladding—Metal, and AS 4040.2—1992 resistance to Wind Pressure For Non-Cyclonic Regions. The pressure capacities for serviceability are based on a deflection limit of (span/120) + (maximum fastener pitch/30). The pressure capacities for strength have been determined by testing the cladding to failure (ultimate capacity). These pressures are applicable when the cladding is fixed to a minimum of 1.0 mm, G550 steel.

ROOF DRAINAGE (length of sheet in m')

Rainfall Intensity (mm/hour)	Slope (°)			
	3	5	7	10
100	796	991	1181	1358
200	398	495	591	679
300	265	330	394	453
400	199	248	295	339
500	159	198	236	272

FASTENING METHOD

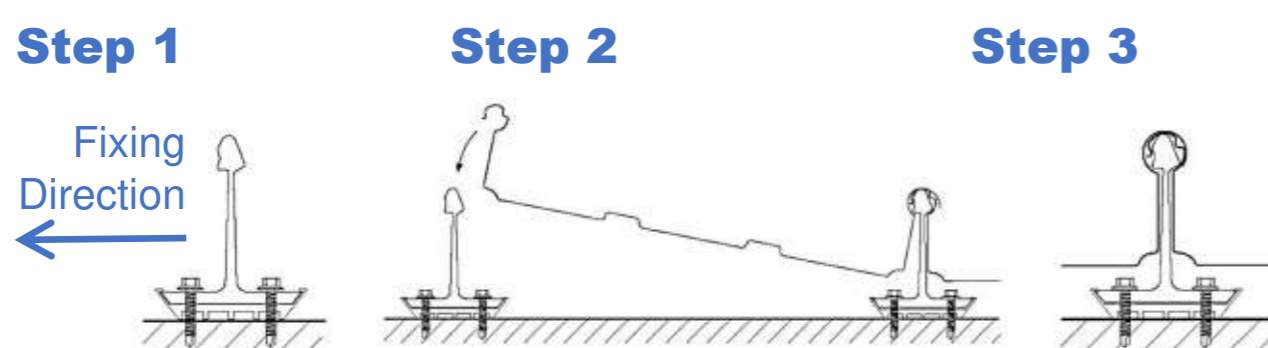

Fixing Clip

FLEX-LOK® is anchored onto the purlins with heat insulated concealed clips. Pay attention to the correct direction.

Fixing male and female ribs onto the clips

Place the female rib overlapping on the male rib from the previous sheet.

Lock-up (Seam)

Seam the ribs using machine on site.

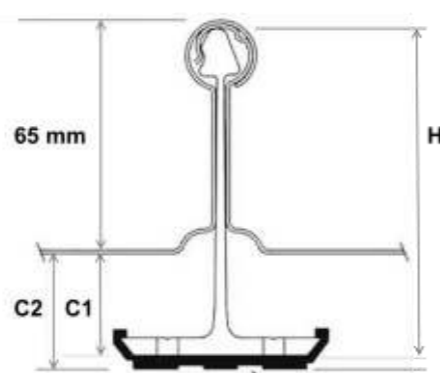

FLEX-LOK® Clips are extruded from structural grade aluminium.

H: height of clip without thermal pad; C1: cavity without thermal pad; C2: cavity with thermal pad

Thermal Pad

Specially engineered thermal pad slides neatly onto base of the clip which can reduce or eliminate thermal bridging effects.

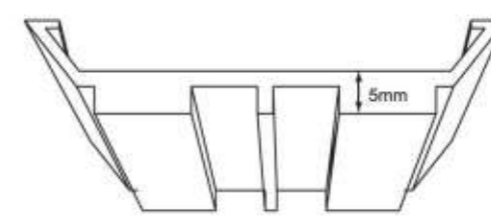

Thermal barrier pad 5 mm thick

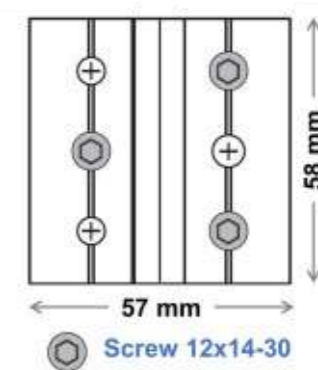

FLEX-LOK® Mechanical & Hand Seamer

LYSAGHT® FLEX-LOK® system seamed onto the clips using a mechanical seaming process. The first 200 – 300 mm should be hand crimped to enable the seamer to be clamped onto the sheet.

OVERLAPPING

LYSAGHT® FLEX-LOK® is not recommended to be end-lapped. Ideally long length sheets from a mobile rollformer should be used where possible. If the need for end-lapping can not be avoided, contact us for guidance.

MANUFACTURING

LYSAGHT® FLEX-LOK® produced in Cibitung and Sidoarjo factory.

Also available in extra long lengths, produced by our on-site mobile rollformer/roll on-site. This service is available based on enquiry.

COLOR CHOICE

Standard & Non-standard colors can be selected from Colorbond® brochure available in www.colorbond.id/product.

CERTIFICATION

- Green Label Indonesia
- TKDN



CONTACT US AT

- ✉ sales@paramasteel.id
- ☎ 021 5853 738
- ☎ +62 821 1273 1111



FOLLOW US AT

- 📷 [parama_id](#)
- 📺 [paramasteel.id](#)

VISIT US

Perkantoran Taman Kebon Jeruk Intercon, Blok AA4 No. 16-18, Meruya Selatan, Jakarta Barat – 11650

WWW.LYSAGHTASEAN.COM

® product and product brand names are registered trademarks and ™ product and product brand names are trademarks of BlueScope Steel Limited. The LYSAGHT® range of products is exclusively made by or for BlueScope Steel Limited. BlueScope and the BlueScope brand mark are registered trademarks of BlueScope Steel Limited.

© PT NS BlueScope Lysaght Indonesia May 2022. All rights reserved.